

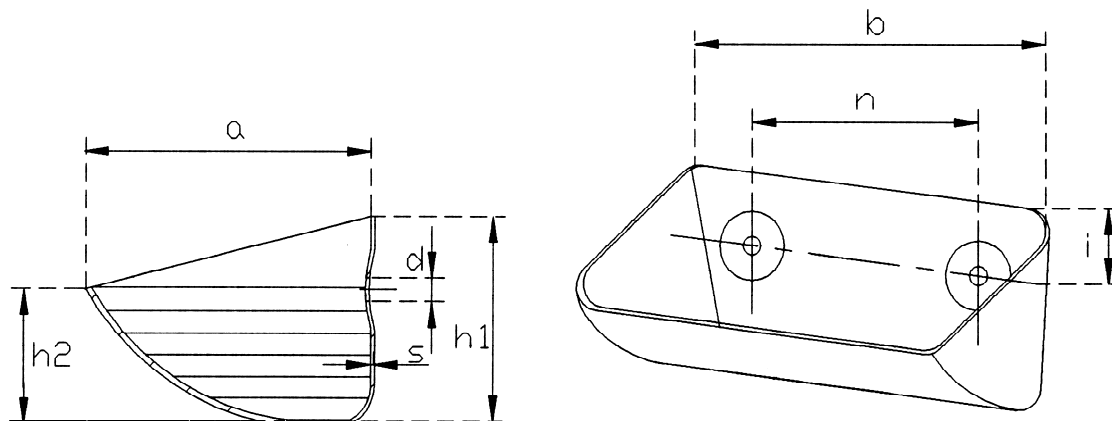

## SYSTEM C GEPRESST



### MATERIAL:

- STAHL
- EDELSTAHL
- ALUMINIUM
- BESCHICHTET
- VERZINKT
- EMAILLIERT

b	a	s	h1	Inhalt		max. B/m	d	n	i
				netto l	brutto l				
	mm	mm	mm				mm	mm	mm
100	86	1,0	60	0,21	0,31	16,0	8,0	50	18
120	100	1,0	72	0,40	0,55	13,5	9,0	67	21
130	110	1,5	76	0,49	0,61	12,5	9,0	70	22
140	115	1,5	86	0,65	0,85	11,0	9,0	86	24
160	125	1,5	90	0,85	1,15	10,5	9,0	101	25
180	140	1,5	88	0,96	1,33	11,0	9,0	100	32
200	140	1,5	100	1,25	1,75	9,5	11,0	131	28
230	160	2,0	105	1,88	2,31	9,0	11,0	120	35
250	150	2,0	107	1,95	2,60	9,0	11,0	2x 77	30
280	160	2,0	105	2,29	2,98	9,0	11,0	2x 80	37
300	180	2,0	129	3,50	4,60	7,5	11,0	2x 100	35
330	210	2,5	130	3,95	5,65	7,5	11,0	2x 120	38
350	188	2,5	134	4,05	5,75	7,0	11,0	3x 90	37
370	214	2,5	154	5,35	7,80	6,0	13,0	3x 90	38